

# HYVA<sup>®</sup>LIFT

"COALAN"  
roll height 195 mm



Hyva moves your world  
[www.hyva.com](http://www.hyva.com)

“Coalan” Capacity 200kN (-S) H = 1570 mm CH = 1050 mm

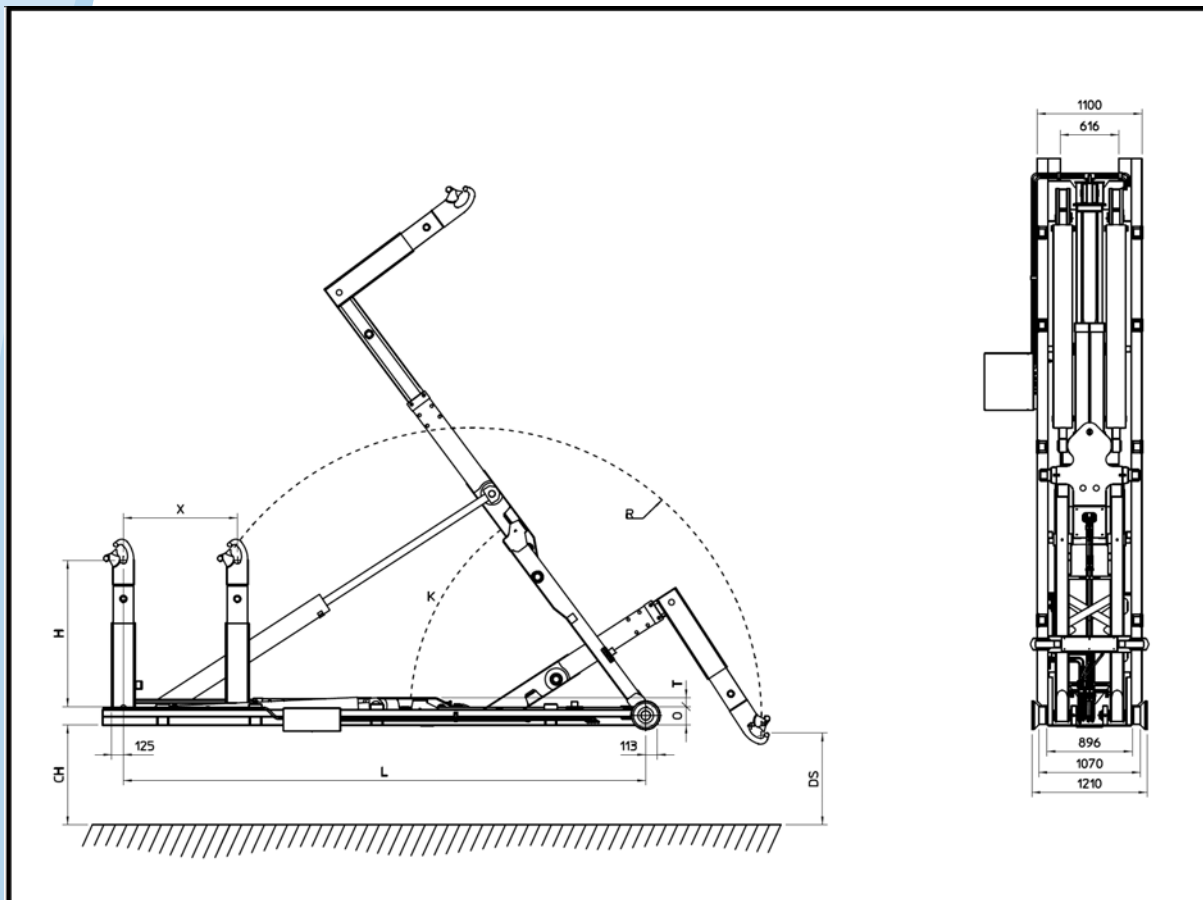

| TYPE:  | COALAN<br>20-53-S | COALAN<br>20-55-S | COALAN<br>20-58-S | COALAN<br>20-60-S | COALAN<br>20-62-S | COALAN<br>20-65-S |
|--|-------------------|-------------------|-------------------|-------------------|-------------------|-------------------|
| X (mm)   | 1100              | 1200              | 1100              | 1300              | 1300              | 1400              |
| L (mm)   | 5300              | 5500              | 5800              | 6000              | 6200              | 6500              |
| O (mm)   | 195               | 195               | 195               | 195               | 195               | 195               |
| K  | 55°               | 53°               | 49°               | 49°               | 49°               | 50°               |
| R (mm)   | 3070              | 3070              | 3153              | 3153              | 3319              | 3319              |
| T (mm)   | 100               | 100               | 100               | 100               | 100               | 100               |
| Weight <sup>1</sup> (kg)                         | 2425              | 2500              | 2575              | 2600              | 2625              | 2825              |
| DS (mm)  | 990               | 990               | 1043              | 1043              | 1151              | 1151              |
| Min./max. container length (mm)                  | 4300-<br>6400     | 4400-<br>6600     | 4800-<br>6900     | 4800-<br>7100     | 5000-<br>7300     | 5300-<br>7600     |
| Loading (operating time) <sup>2</sup> (s)        | 39                | 40                | 39                | 40                | 46                | 49                |
| Unloading (operating time) <sup>2</sup> (s)      | 49                | 50                | 53                | 54                | 59                | 63                |
| Tipping (time) <sup>2</sup> (s)                  | 43                | 43                | 46                | 46                | 51                | 55                |
| Fast unloading (operating time) <sup>2</sup> (s) | 19                | 21                | 21                | 22                | 22                | 24                |

H = Hook height, CH = Chassis height, DS = Lowest pick up point (depending on hook- and chassis height)

<sup>1</sup> Rough estimation based on a standard system, filled with oil and without mounting kit accessories.

<sup>2</sup> Rough estimation based on PTO type C, pump 80 l/min., motor 1200rpm, PTO transmission i = 1.0 and dependent on cylinder thickness.

## “Coalan” Capacity 220kN (-S) H = 1570 mm CH = 1050 mm

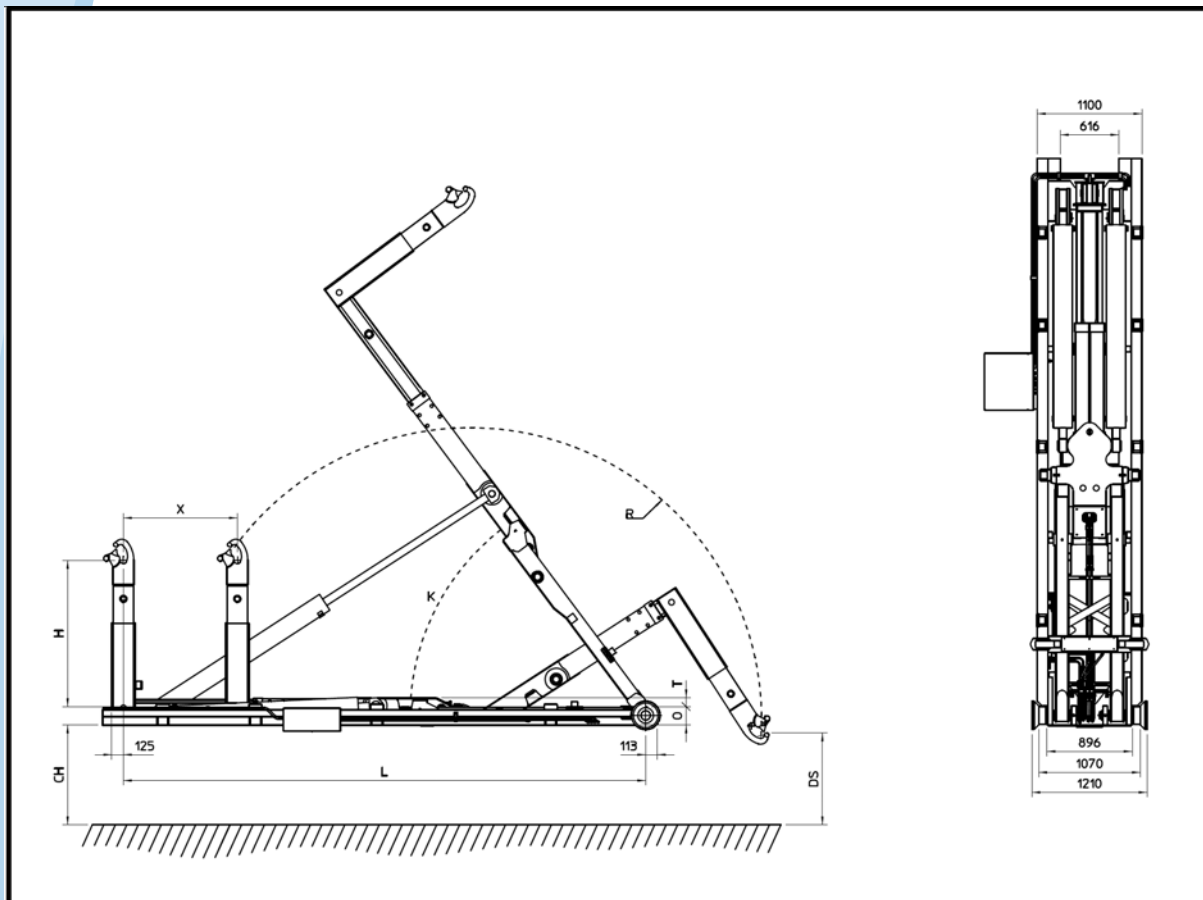

| TYPE:  | COALAN<br>22-53-S | COALAN<br>22-55-S | COALAN<br>22-58-S | COALAN<br>22-60-S | COALAN<br>22-62-S | COALAN<br>22-65-S |
|--|-------------------|-------------------|-------------------|-------------------|-------------------|-------------------|
| X (mm)   | 1100              | 1200              | 1100              | 1300              | 1300              | 1400              |
| L (mm)   | 5300              | 5500              | 5800              | 6000              | 6200              | 6500              |
| O (mm)   | 195               | 195               | 195               | 195               | 195               | 195               |
| K  | 55°               | 53°               | 49°               | 49°               | 49°               | 50°               |
| R (mm)   | 3070              | 3070              | 3153              | 3153              | 3319              | 3319              |
| T (mm)   | 100               | 100               | 100               | 100               | 100               | 100               |
| Weight <sup>1</sup> (kg)                         | 2425              | 2500              | 2575              | 2600              | 2625              | 2825              |
| DS (mm)  | 990               | 990               | 1043              | 1043              | 1151              | 1151              |
| Min./max. container length (mm)                  | 4300-<br>6400     | 4400-<br>6600     | 5000-<br>6900     | 5000-<br>7100     | 5000-<br>7300     | 5850-<br>7600     |
| Loading (operating time) <sup>2</sup> (s)        | 39                | 40                | 39                | 40                | 46                | 49                |
| Unloading (operating time) <sup>2</sup> (s)      | 49                | 50                | 53                | 54                | 59                | 63                |
| Tipping (time) <sup>2</sup> (s)                  | 43                | 43                | 46                | 46                | 51                | 55                |
| Fast unloading (operating time) <sup>2</sup> (s) | 19                | 21                | 21                | 22                | 22                | 24                |

H = Hook height, CH = Chassis height, DS = Lowest pick up point (depending on hook- and chassis height)

<sup>1</sup> Rough estimation based on a standard system, filled with oil and without mounting kit accessories.

<sup>2</sup> Rough estimation based on PTO type C, pump 80 l/min., motor 1200rpm, PTO transmission i = 1.0 and dependent on cylinder thickness.