

[6]^{PM}

CLASSIC



[elevate to the highest power]^{pm}

**EQUIPAGGIAMENTO DI SERIE - CONFIGURATION
STANDARD EQUIPMENT - CONFIGURATION EQUIPEMENT
STANDARD - SERIENMÄSSIG - EQUIPO DE SERIE**



Cremagliera
Slewing by rack
Rotation avec crémaillère
Zahnstangenschwenkwerk
Rotación con cremallera



Martinetti stabilizzatori rotanti manuali
Manual flip up outriggers
Vérins pivotant manuellement
Manuell schwenkbare Abstützylinder
Brazos estabilizadores giratorios manuales



Bracci stabilizzatori a sfilo manuale
Manual pull-out outrigger booms
Bras stabilisateurs avec extension manuelle
Manuelle Abstützungen
Brazos estabilizadores a salida manual



Uscita sequenziale sfilo bracci
Sequential extension booms' output
Sortie bras séquentiel
Anzahl der Ausschubzylinder
Salida secuencial de los brazos



Dispositivo automatico sicurezze stabilizzatori inserite
Safety Kit for outriggers
Dispositif de sécurité stabilisateurs
Sicherheitskit für die Abstützungen
Kit de Seguridad para estabilizadores

Tutte le gru PM sono coperte da polizza assicurativa internazionale per la responsabilità verso terzi.
All PM Cranes are covered by international insurance policy for civil liability third party.
Toutes les grues sont couvertes par une police d'assurance internationale de responsabilité civile envers tiers.
PM Krane sind durch eine internationale Haftpflichtversicherung gegen Dritte abgesichert.
Todas las grúas PM cuentan con una póliza de seguros internacional contra las responsabilidades civiles hacia terceros.

- Disponibile fino a 4 sfili idraulici
- Available up to 4 hydraulic extensions
- Disponible jusqu'à 4 extensions hydraulique
- Bis zu 4 hydraulische Ausschübe erhältlich
- Disponible hasta 4 extensiones hidráulicas

OPTIONAL



Scambiatore di calore
Oil cooler
Refroidisseur
Ölkühler
Enfriador de aceite



Canaline raccogli tubo
Activations with racks
Activations avec gouttières
Schlauchketten für Zusatzgeräte
Bandejas



Blocco Rotazione Elettroidraulico
Slewing limiter locking device electronic/hydraulic
Soupape d'arrêt rotation électronique/hydraulique
Elektronische Schwenkbereichsbegrenzung
Bloqueo rotación electrónico/hidráulico



Serbatoio
Oil tank
Réservoir
Öltank
Depósito de Aceite



Prolunghe manuali
Manual extensions
Rallonges manuelles
Mechanische Verlängerungen
Prolongas manuales



LMU: sistema di controllo CE per prolunghe meccaniche
LMU Device: control system for manual extensions
Dispo LMU: système de contrôle CE pour rallonges manuelles
LMU: CE Kontrollsystem für mechanische Verlängerungen
LMU: Sistema de control CE por prolongas manuales

EN12999

CONFORME ALLE NORME DI SICUREZZA EU
IN ACCORDANCE TO THE EU SAFETY STANDARDS
CONFORME AUX NORMES DE SECURITE EU
GEMÄß EU SICHERHEITSRICHTLINIEN
CONFORME CON LAS NORMAS DE SEGURIDAD EU

H1B3

CLASSE DI SOLLECITAZIONE A FATICA H1B3
FATIGUE-TESTED IN CLASS H1B3
ESSAIS EN FATIGUE EN CLASSE H1B3
ERMÜDUNGSTEST NACH KLASSE H1B3
COMPROBACIÓN DE FATIGA EN LA CLASE H1B3

[3]

3 ANNI DI GARANZIA SULLE PARTI STRUTTURALI
3 YEARS OF WARRANTY ON THE STRUCTURAL PARTS
3 ANS DE GARANTIE SUR LES PARTIES STRUCTURELLES
3 JAHRE GARANTIE AUF STRUKTURBAUTEILE
3 AÑOS DE GARANTÍA EN LAS PARTES ESTRUCTURALES

[IA]

DICHIARAZIONE DI CONFORMITÀ DEL PRODUTTORE
DECLARATION OF CONFORMITY OF THE MANUFACTURER
DECLARATION DE CONFORMITE DU PRODUCTEUR
KONFORMITÄTSERKLÄRUNG DES HERSTELLERS
DECLARACIÓN DE CONFORMIDAD DEL PRODUCTOR

PQS

SISTEMA DI VERNICIATURA DI QUALITÀ CERTIFICATA
CERTIFIED PAINTING QUALITY SYSTEM
SYSTÈME DE PEINTURE DE QUALITÉ CERTIFIÉ
ZERTIFIZIERTES QUALITÄTS-LACKIERSYSTEM
SISTEMA DE BARNIZADO DE CALIDAD CERTIFICADA

- Martinetti stabilizzatori rotanti manuali
- Manual tilting outriggers
- Vérins pivotant manuellement
- Manuell schwenkbare Abstützungen
- Brazos estabilizadores giratorios manuales



6021

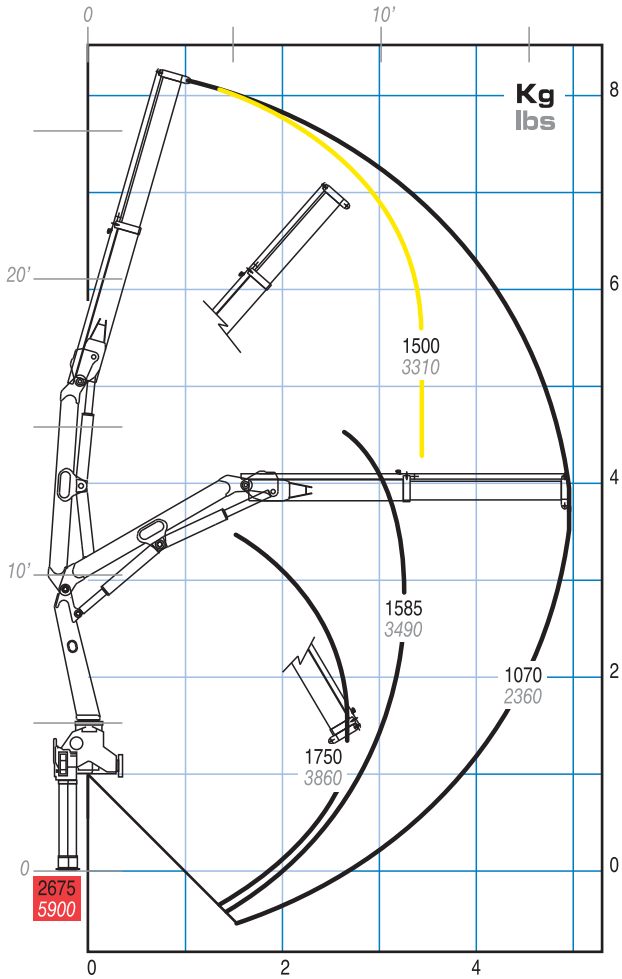

6022

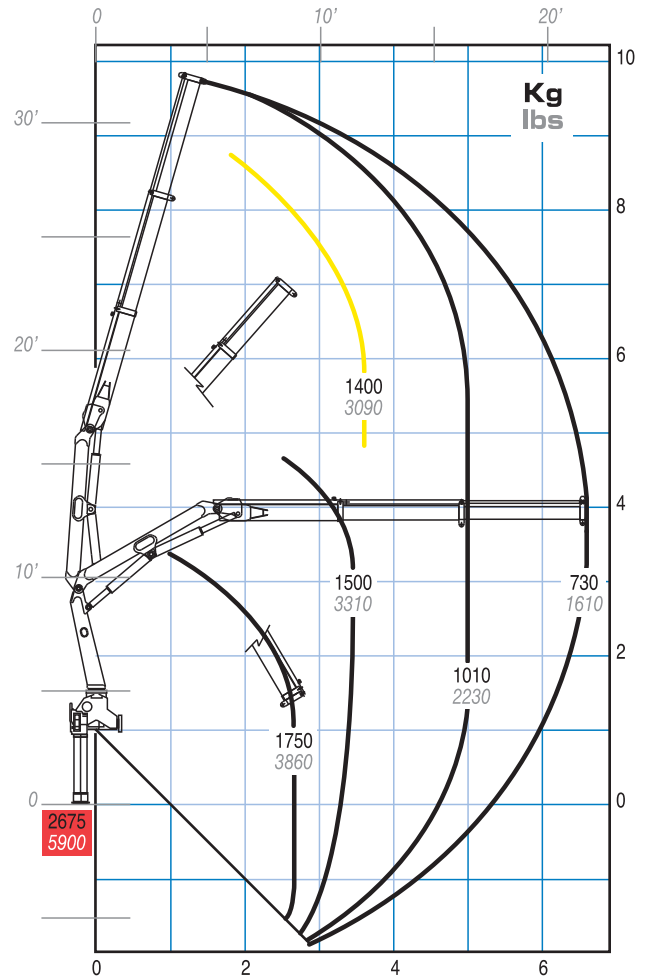

6023

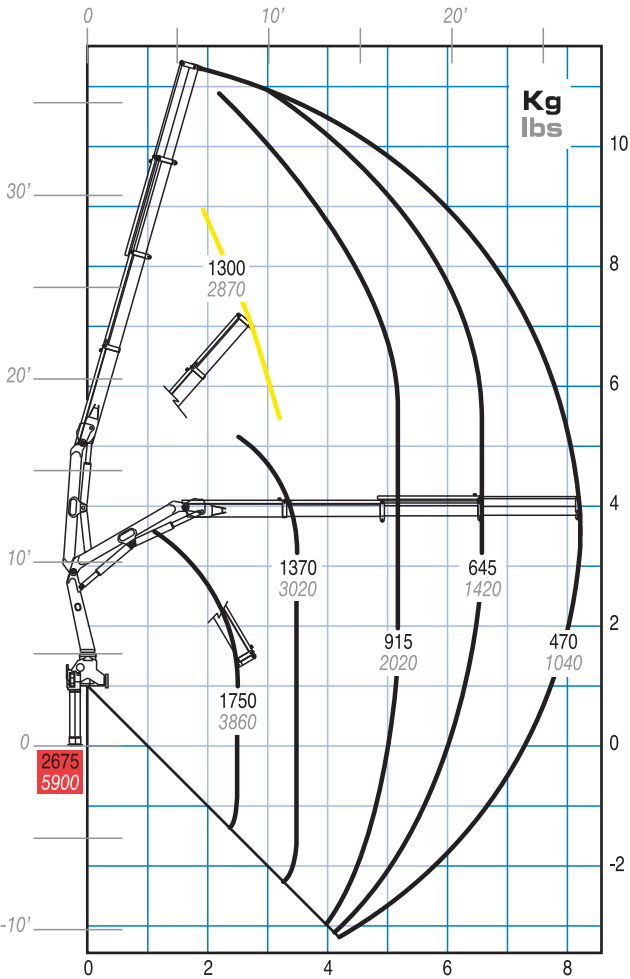

6024

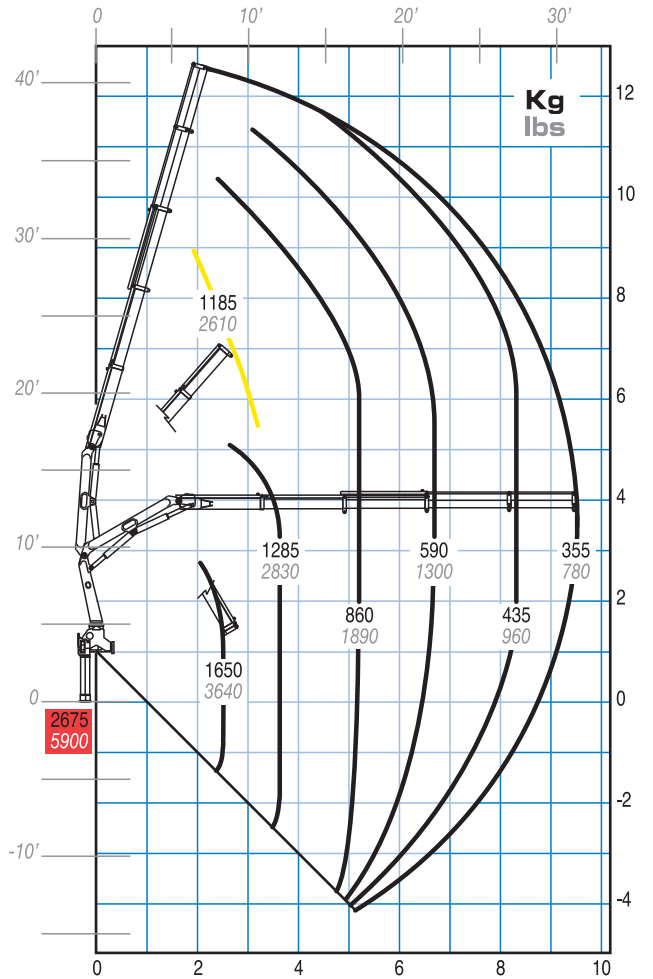

— Portata massima passante per l'orizzontale - Max. capacity from horizontal to vertical - Capacité maxi passant par l'horizontale - Max. Tragkraft von horizontal bis zu vertical - Máxima capacidad de la horizontal a la vertical
■ Portata massima nominale al gancio fisso - Max. nominal capacity with fixed hook - Capacité maxi nominale au crochet fixe - Max. Nenntragkraft an der inneren Hakenbefestigung - Capacidad máxima en el gancho fijo

mm
ft

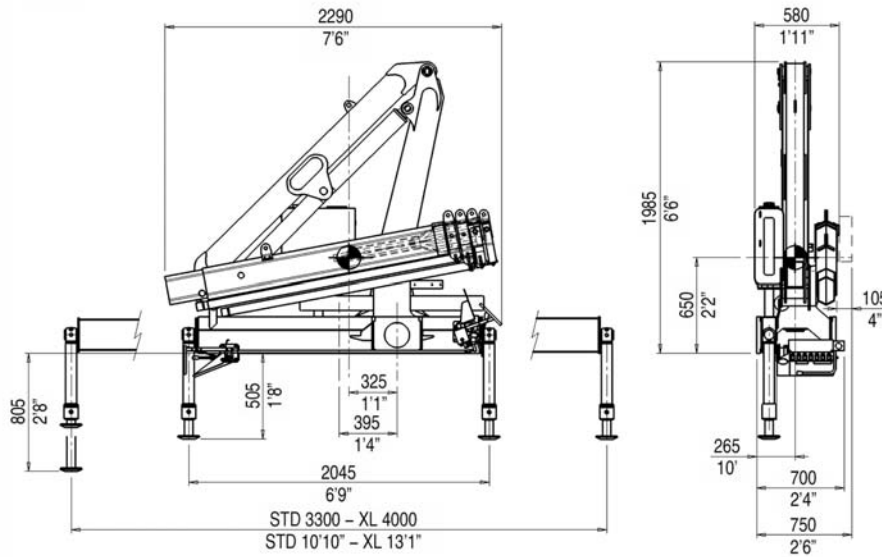

Abbinamento gru/veicolo Trucking crane combination Accouplement grue/véhicule Kran zusammen mit LKW Combinación grúa/camión

PTT/GVW	6		
6,5 ton			2 stabilizzatori STD 2 outriggers STD 2 stabilisateurs STD 2 Abstützungen STD 2 gatos de apoyo STD
7,5 ton			
8,0 ton			
10,0 ton			2 stabilizzatori XL 2 outriggers XL 2 stabilisateurs XL 2 Abstützungen XL 2 gatos de apoyo XL
12,0 ton			
13,5 ton			2 stabilizzatori XL 2 outriggers XL 2 stabilisateurs XL 2 Abstützungen XL 2 gatos de apoyo XL
15,0 ton			
18,0 ton			
19,0 ton			4 stabilizzatori 4 outriggers 4 stabilisateurs 4 Abstützungen 4 gatos de apoyo
26,0 ton			4 stabilizzatori 4 outriggers 4 stabilisateurs 4 Abstützungen 4 gatos de apoyo
32,0 ton			4 stabilizzatori 4 outriggers 4 stabilisateurs 4 Abstützungen 4 gatos de apoyo

PTT: Peso totale a terra - G.V.W. - P.T.A.C.
LKW Gesamtgewicht - Peso total del vehículo

		6021	6022	6023	6024
Momento di sollevamento massimo - Maximum lifting moment - Moment de levage maxi - Max. Lastmoment - Momento de elevación máxima	tm	5,3	5,3	4,8	4,6
	ft. lbs	38410	38180	34680	33460
Sbraccio oleodinamico - Maximum hydraulic reach - Allongement hydraulique Hydraulische Reichweite, Standard - Alcance hidráulico orizzontale - horizontal - horizontal - horizontal verticale - vertical - vertical - vertical - vertical	m	5,10	6,80	8,40	9,65
	ft	16'9"	22'4"	27'7"	31'8"
	m	8,15	9,70	11,30	12,60
	ft	26'9"	31'10"	37'1"	41'4"
Sbraccio con prolunghe - Maximum reach with manual extensions - Allongement avec rallonges manuelles - Reichweite, manuelle Verlängerungen - Alcance con prolongas manuales orizzontale - horizontal - horizontal - horizontal verticale - vertical - vertical - vertical - vertical	m	11,00	11,00	11,00	10,95
	ft	36'1"	36'1"	36'1"	35'11"
	m	13,85	13,85	13,85	13,80
	ft	45'5"	45'5"	45'5"	45'3"
Impianto oleodinamico - Hydraulic system - Circuit hydraulique - Hydraulikanlage - Sistema hidráulico portata raccomandata - recommended oil flow - débit recommandé - empfohlene Fördermenge - caudal requerido pressione massima - rated pressure - pression max - Betriebsdruck - presión máxima capacità del serbatoio - tank capacity - capacité du réservoir - Tankinhalt - capacidad del depósito de aceite	l/min	20	20	20	20
	gals/min	5	5	5	5
	Mpa	27,5	27,5	27,5	27,5
	Psi	3990	3990	3990	3990
	l	64	64	64	64
Gals	17	17	17	17	
Gruppo di rotazione - Slewing system - Rotation - Schwenksystem - Sistema de giro angolo di rotazione - slewing angle - angle de rotation - Schwenkbereich - ángulo de giro coppia di rotazione - slewing moment - couple de rotation - Schwenkmoment - momento de giro pendenza massima di lavoro - max. working heel - devers max de travail - max Arbeitsneigung - inclinación máxima de trabajo	°	390	390	390	390
	kNm	7,5	7,5	7,5	7,5
	ft. lbs	5530	5530	5530	5530
	%(°)	8,7(5)	8,7(5)	8,7(5)	8,7(5)
Peso della gru standard - Standard crane weight Poids de la grue standard - Eigengewicht - Peso de la grúa estandar Con serbatoio non rifornito - Empty oil tank - réservoir huile non garni - Leerer Öltank - depósito de aceite vacío	kg	728	775	822	859
	lbs	1605	1710	1810	1890

I dati tecnici possono essere aggiornati senza preavviso
Technical data can be revised without prior notice

Les données techniques peuvent être modifiées sans
preavis

Technische Änderungen vorbehalten
Reservado el derecho de modificaciones